



NRG Turbine Control Yaw Vane 2 Ch, PNP, 8.0 m

User Manual



NRG Systems, Inc. • 110 Riggs Road • Hinesburg • VT 05461 USA
TEL 802-482-2255 • FAX 802-482-2272 • EMAIL sales@nrgsystems.com

Introduction

The NRG Turbine Control Yaw Vane is a rugged wind direction sensor designed specifically for wind turbine control. The vane base is fixed to the turbine nacelle with relative “north” facing directly out toward the blades. Rotation of the vane head interrupts optical sensors and indicates yaw errors by providing output signals relative to the fixed vane base.

The NRG Turbine Control Yaw Vane is reliable in heavy and light winds. It is rugged enough to accurately measure winds in excess of 90 meters per second (200 miles per hour), yet its low moment of inertia allows it to respond to winds as low as 2.0 m/s.

PNP Output Circuit Operation

The NRG Turbine Control Yaw Vane has two output signals. The outputs are “PNP”, which means that an active output sources current from the sensor supply to the load on the output.

Typically, these outputs are used by connecting the output to a grounded load such as a relay or optical isolator in the turbine controller. The active outputs power the relay coil or opto-isolator loop, and when the output is inactive, the load is off.

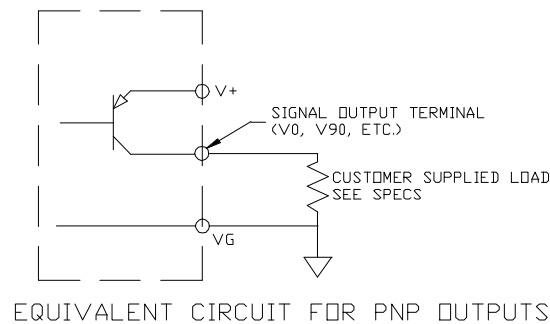

The opto-interrupters require an external power supply to operate the LED lamps. The sensor signals are powered through an additional two wires: the red (excitation) and black (ground) wires.

ESD, Circuit Protection, and Cautions

- Do not apply greater than 30 Volts to the outputs at any time.
- We suggest that you not mount the sensor until the proper grounding is available. When you mount the sensor, protect the signal wires and connect the ground first. After connecting to ground, attach the signal wires from the sensor.
- There are internal reverse-protection diodes on each output. If the outputs are pulled below ground, the diodes will clamp the output to ground.
- Do not apply constant reverse voltages to the outputs. The internal diodes are intended only to protect the sensor outputs from transient reverse voltages, for example, the inductive turn-off spike caused by driving reed-relay coils directly from the yaw vane’s outputs.

Interpreting Output Signals – 2 Channels

The diagrams and table below indicate when each of the two outputs is active (1) or inactive (0), for each relative direction the nose is pointing. For example, if the vane nose is pointing 35 degrees relative to the base, the V90 output (green wire) will become active.

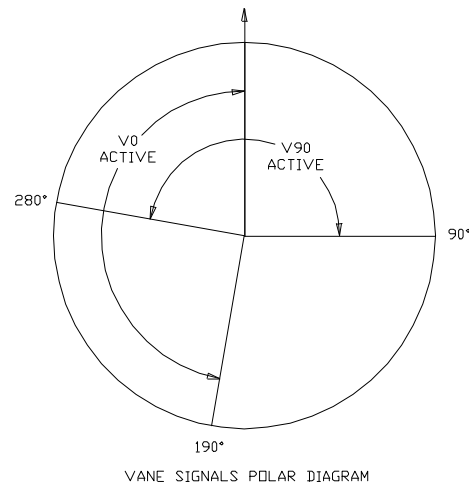
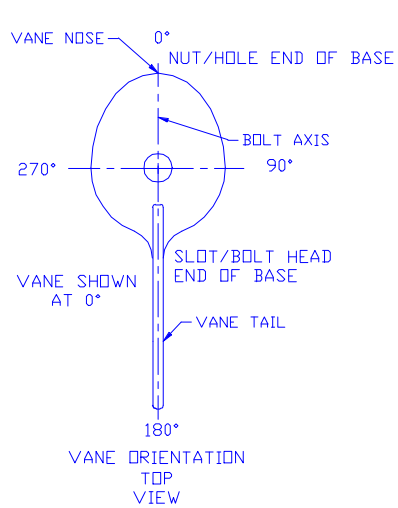

Azimuth Range (clockwise degrees)	Output Signals	
	V90	V0
0 to 90	1	0
90 to 190	0	0
190 to 280	0	1
280 to 0	1	1

Output Signal	Wire Color
V90	Green
V0	White

Installation

1. Tape the ends of the cable to prepare for feeding the cable through the mounting boom. Maintain isolation of the signal leads from the boom. Remove the nut and bolt from the base of the unit. Feed the cable through the mounting boom until the sensor is on the boom. Align the bolt hole (not the slot) in the base with the hole in the boom so that the hole in the base points forward toward the rotor blades.
2. Check that the sensor is secure against the top of the boom. Insert the bolt into the slot side of the base. Place the nut on the end of the bolt and tighten.
3. Just remember “Nut is North”. In other words, the bolt hole (not the slot) and nut define azimuth 0, which is normally oriented toward the nose/front of the turbine. North and azimuth 0 mean the same thing.
4. Using the notations on the individual wires, connect the ground (common) lead to your controller first. Then connect the signal leads. Connect power last, especially if power is on during connection. Confirm input throughout the range of operation.

Sensor and Mounting Outline

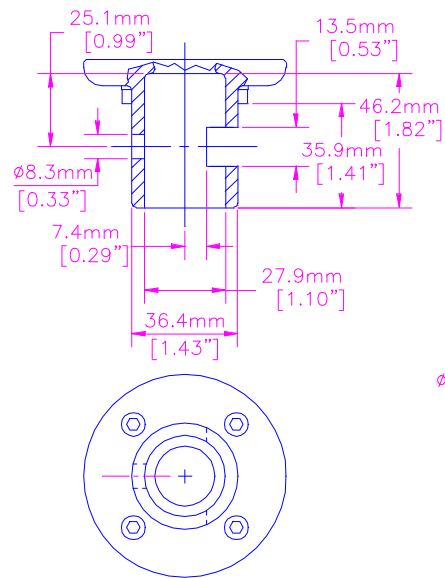
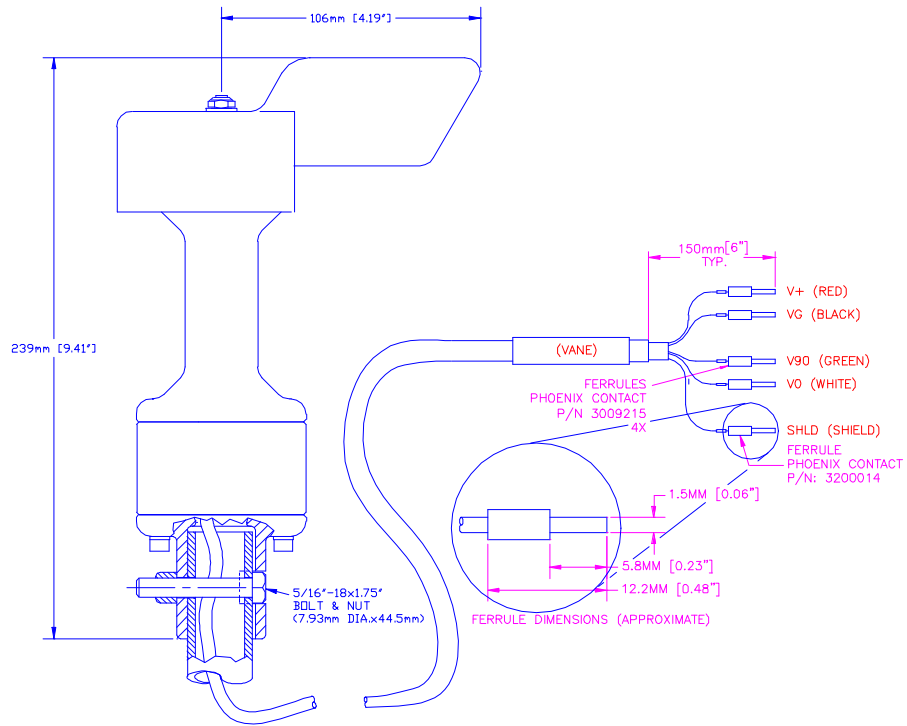

MOUNTING BASE DIMENSIONS

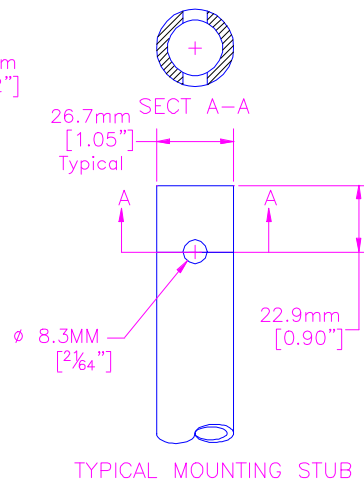

Specifications

Description	Sensor type	yaw error vane
	Applications	wind turbine yaw control
	Sensor range	mechanical range 360°
Output signal	Signal type	<ul style="list-style-type: none"> • PNP outputs: active high output sources current to the sensor output load from the sensor power supply; inactive low output is pulled down to ground by sensor output load • each output can source up to 25 mA to within 1 V of the supply voltage • inactive output leakage is less than 100 uA
	Transfer function	2 outputs; switch points at relative wind 0°, 90°, 190°, 280°
	Accuracy	+/- 3 deg
Power requirements	Supply voltage	8 VDC to 24 VDC
	Supply current	30 mA typical; sensor power draw is internally regulated
Response characteristics	Threshold	<2 m/s
Installation	Mounting	mounts to a 27 mm (1.05 inch) diameter pipe (3/4 inch pipe size) with a 5/16 inch nut and bolt; cabling exits into mounting pipe
	Tools required	13 mm (0.5 inch) nut driver
Environmental	Operating temperature range	-40 °C to 60 °C (-40 °F to 140 °F)
	Operating humidity range	0 to 100% RH
Physical	Connections	Sensor Cable <ul style="list-style-type: none"> • red: power • black: ground • white: V0 • green: V90
	Cable length	8.0 m (26.2 feet) signal cable
	Weight	1.23 kg (2.7 pounds) not including cable
	Dimensions	<ul style="list-style-type: none"> • overall assembly height: 239 mm (9.41 inches) • body diameter: 70 mm (2.75 inches) • swept diameter: 212 mm (8.38 inches) • center to tail radius: 106 mm (4.19 inches)
Materials	Body	cast aluminum with black anodized finish and heat-resistant black paint
	Shaft	centerless ground, stainless steel
	Bearing	<ul style="list-style-type: none"> • upper: sealed, stainless steel, ball bearing with application specific lubrication • lower: modified teflon bearing
	Wing	precision balanced aluminum with black anodized finish and heat-resistant black paint
	Cable	<ul style="list-style-type: none"> • Signal: 4 conductor 22 AWG, Teflon jacket with braid shield and drain
	Enclosure	<ul style="list-style-type: none"> • sealed to IP55 • sensor electronics epoxy encapsulated to IP65
	Signal generator	epoxy encapsulated inside glass reinforced thermoplastic shell
	Base	cast aluminum with black anodized finish and heat-resistant black paint